



REFERENCE INSTRUCTION LETTER

TO: All Operators	FROM: Customer Support Engineering	CONTROL NO: RIL # GX-0084	REVISION: NC
ATTN: Aircraft Maintenance	ORIGINATOR: Michel Kennedy	PAGE: 1 of 1	
PHONE NO: N/A	PHONE NO: 514-855-6584	A/C MODEL: BD-700-1A11	A/C S/N: 9001&subs
FAX NO: N/A	FAX NO: N/A	ATA NO: 35-00	
DATE OF REQUEST:	PUBLICATION AFFECTED:		
TITLE: Optional Leak Test of the Oxygen System Using Helium			
REFERENCE:			
ISSUE: To allow operators to use Helium leak detector to detect leaks in the oxygen system			
RESOLUTION: It is permissible to use the attached procedure in order to detect leaks in the oxygen system that could not be found by performing AMM leak test procedure using leak detection compound.			
PREPARED BY:		APPROVAL:	
Print name:	Michel Kennedy	Print name:	Vinod Mistry
Signature:		Signature of	
Date:	Feb 19, 2013		<i>19th Feb 2013.</i>

This document can be used as Instructions for Continued Airworthiness until such time as a Temporary Revision or Manual Revision is issued by Technical Publications. The current status of open Reference Instruction Letters is published in each issue of the Customer Forum and Newsletter, and on the CIC web Site (<http://www.cic.bombardier.com/>).

Optional Leak Test of the Oxygen System using Helium

Description

1. Perform the optional leak test that follows only to detect leaks that have not been found using the leak tests currently in the AMM.
2. Follow the AMM instructions for the removal/installation procedures and return to service of any components of the oxygen system.
3. This procedure uses Helium leak detection method.
4. The oxygen control panel needs to be removed and the lines capped when performing the leak detection test using helium.

Reference Information

TASK 12-13-01-614-801	Servicing of the Flight-Crew Oxygen System
TASK 35-10-00-910-801	Oxygen System Safety Precautions
TASK 35-21-01-000/400-801	Removal/Installation of the Passenger Oxygen Control-Panel
SPM-MM-20-50-00-000/400-801	Removal/installation of Lockwire
TASK 35-10-00-790-801	Leak Test of the Crew Oxygen System
TASK 35-10-00-400-801	Installation of the Oxygen Supply Tubes
TASK 35-11-01-000/400-801	Removal/Installation of the Oxygen Storage Cylinder and Regulator
TASK 35-11-01-790-801	Leak Test of the Oxygen Storage Cylinder and the Regulator
TASK 35-11-09-790-801	Leak Test of the Oxygen Mask Stowage-Boxes
TASK 35-12-01-790-801	Leak Test of the Oxygen Ground Servicing Panel Pressure Gauge
TASK 35-12-05-790-801	Leak Test of the Oxygen Filler Valve
TASK 35-12-09-790-801	Leak Test of the Oxygen Pressure Transducer
TASK 35-12-13-790-801	Leak Test of the Oxygen Check Valve
TASK 35-12-17-790-801	Leak Test of the Oxygen Pressure Switch
TASK 35-20-05-790-801	Leak Test of the Therapeutic Oxygen Valve
TASK 35-21-01-790-801	Leak Test of the Passenger Oxygen Control Panel
TASK 52-45-05-000/400-801	Removal/Installation of the Forward Equipment Compartment Access Panels

Tools and Equipment

Reference	Designation
ASM 102S (or equivalent)	Helium Detector (Adixen)
PHD-4 (or equivalent)	Helium Detector (Varian Inc)
Gas Check 3000 handheld (or equivalent)	Helium Detector (TM Electronics)
GSE 12-30-02	Adapter – Oxygen System
GSE 12X-13-01	Oxygen Service Cart

Consumable Materials

Reference	Designation	Manufacturer's reference
254824902	Helium Bottle	Praxair/Airgas
CG-350 style	Tracer Gas Pressure regulator	0 to 100 psi delivery pressure, 3000 psi maximum rated inlet pressure
PRS40124	Prostar Platinum (regulator)	Praxair / 0 to 400 psi delivery max out 250
	Caps, couplings, unions, reducer	Commercially available
MIL-L-25567	Compound, Leak Detection	Commercially available

Note: You can use alternative components provided that the specifications are equivalent

WARNING: ALL LINES, FITINGS AND COMPONENTS THAT COME IN CONTACT WITH THE OXYGEN SYSTEM MUST BE FREE OF OILS, GREASE AND SOLVENTS. IF OXYGEN TOUCHES OIL, GREASE OR SOLVENTS, THEY CAN START TO BURN.

Setup

1. Obey all the oxygen system safety precautions (TASK 35-10-00-910-801).
2. Perform the removal of the Forward Equipment Compartment Access Panels (TASK 52-45-05-000-801).
3. Remove the lockwire from the levers of all four oxygen cylinder regulators (SPM-MM 20-50-00-000-801).
4. Set the ON/OFF levers on all four bottles to OFF.
5. Release the oxygen pressure in the supply lines as follows:
 - a) In the flight compartment, push and hold the PRESS TO TEST AND RESET control lever on the stowage box.
 - b) Push the EMERGENCY/PRESS TO TEST flow control knob on the mask regulator.
 - c) Hold until the oxygen flow stops.
 - d) Release the control lever and the flow control knob.
6. Remove of the PASSENGER OXYGEN Control-Panel (TASK 35-21-01-000-801).
7. Install caps on the oxygen supply line to the passenger oxygen control panel. Make sure the caps do not leak.

Procedure

WARNING: BE CAREFUL WHEN YOU DO WORK ON OR NEAR THE CAPILLARY LINES. CAPILLARY LINES CAN BE EASILY DAMAGED. IF THEY ARE DAMAGED, IT CAN CAUSE INJURY TO PERSONNEL AND DAMAGE TO EQUIPMENT

CAUTION: HELIUM "TRACER" GAS MAY NOT BE USED TO LEAK TEST THE OXYGEN BOTTLE/REGULATOR ASSEMBLY, THE TRACER GAS MIXTURE MAY ONLY BE USED IN THE REMAINING SYSTEM PLUMBING /COMPONENTS

1. Disconnect the oxygen line (4) at one oxygen bottle at a time and perform the following:
 - a) Connect the helium bottle regulator to the oxygen line (4).
 - b) Open the helium bottle regulator slowly to a pressure of 30 to 40 psi.
 - c) Allow helium to flow through the pilot, co-pilot and crew member masks to purge the remaining oxygen out of the lines. Use the helium leak detector per the applicable user guide.
 - d) Slowly pressurize the system to 75 psi.
 - e) Close the main valve on the helium bottle.
 - f) Wait 15 minutes to allow the temperature of the gas in the lines to stabilize.
 - g) Record the pressure indicated on the gauge and make sure it remains between 70 to 75 psi.

- h) With the system pressurized between 70 to 75 psi, use the helium leak detector per applicable user guide. Verify all lines, unions, mask, connections, check valves, pressure switches to identify any leaks. Repair any leaks using AMM instructions.
 - i) In the cabin, using the helium leak detector, verify that there is no presence of helium at the therapeutic line connection. If helium is found, replace the therapeutic oxygen valve per AMM instructions.
2. If no leaks are found, repeat the above steps on the capillary lines (3).
 3. If any leaks are found within the oxygen supply tubes or hardware, repair and re-install per AMM instructions TASK 35-10-00-400-801.
 4. Once the leak has been identified and repaired per AMM instructions, release the helium pressure from the oxygen lines.
 5. In the flight compartment, push and hold the PRESS TO TEST AND RESET control lever on the oxygen mask storage-box.
 6. Push the PRESS TO TEST flow control knob on the oxygen mask regulator.
 7. Hold until the helium flow stops.
 8. Disconnect the regulator and helium bottle from the oxygen system line (4).
 9. Per AMM instructions (TASK 35-11-01-400-801), connect the oxygen lines (4) and capillary lines (3) to the oxygen bottle regulators.
 10. Install the PASSENGER OXYGEN Control-Panel (TASK 35-21-01-400-801).
 11. Set the On/OFF levers on the 4 oxygen bottle pressure regulators to ON.
 12. Purge any remaining tracer gas out of the system by allowing full oxygen to flow through the pilot, co-pilot and 3rd crew oxygen masks (if applicable) for 2 minutes each.
 13. Use the helium leak detector to make sure no traces of helium remain in the oxygen flowing out of the pilot, co-pilot and 3rd crew oxygen masks.
 14. Purge all oxygen masks that are installed by STC for a period of 2 minutes. Using the helium leak detector, make sure no traces of helium remain in the oxygen flowing out of the masks.
 15. Operate the therapeutic oxygen system for 2 minutes per SMM instructions.
 16. Install lockwire on the ON/OFF levers on all four pressure regulators (SPM-MM-20-50-00-400-801).
 17. Service the flight crew oxygen system (TASK 12-13-01-614-801) and make sure the oxygen pressure indication on the 4 oxygen storage cylinder and regulator assembly is at the correct pressure (refer to the servicing placard adjacent to the oxygen filler valve).
 18. Apply leak detection compound to all lines, unions and fittings that have been removed or loosened in this troubleshooting procedure. Make sure there are no leaks.

Close Out

1. Remove all tools, equipment and unwanted materials from the aircraft and work area.
2. Install the Forward Equipment Compartment Access Panels (TASK 52-45-05-400-801).

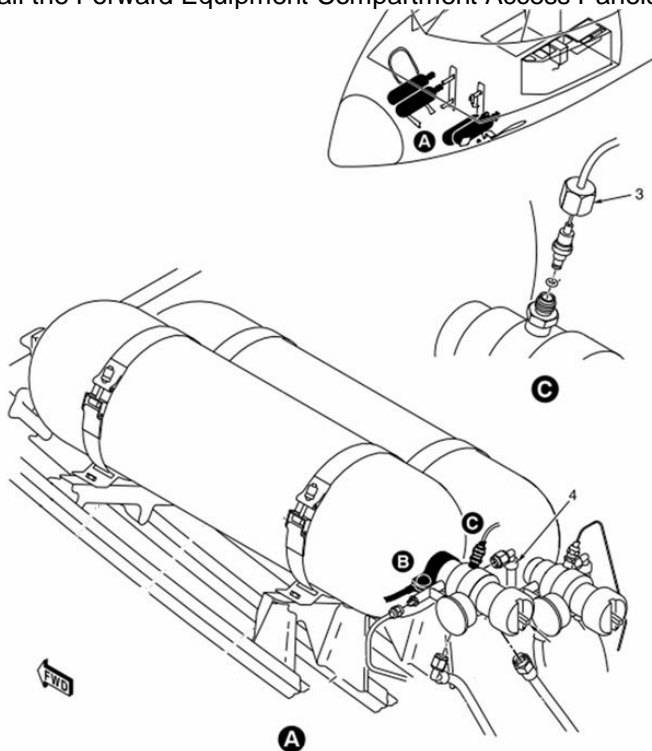

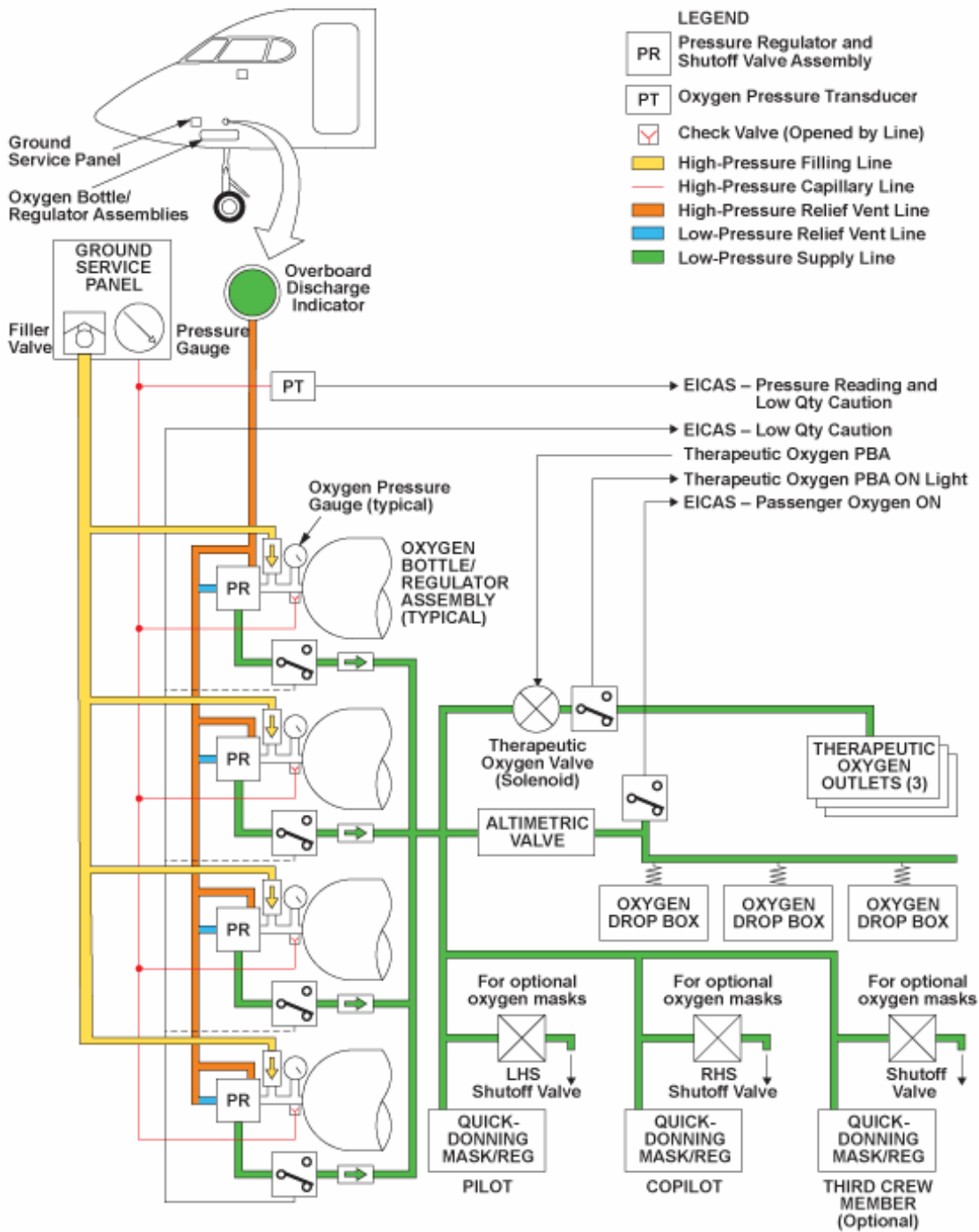

OXYGEN AND OXYGEN MASK SUPPLY – SCHEMATIC