

# Honeywell SERVICE INFORMATION LETTER

Engines, Systems & Services – Phoenix, Arizona

APPLICABLE:

MAINTENANCE  
& ENGINEERING

FLIGHT  
OPERATIONS

FOR ALL AIRFRAME MANUFACTURERS USING  
GENERAL AVIATION, GENERAL PRODUCTS  
AND/OR AUXILIARY POWER UNITS,  
OWNER/OPERATORS, DISTRIBUTORS, SALES  
AND SERVICE ORGANIZATIONS, AND FIELD  
SERVICE REPRESENTATIVES.

**Applicable To:** Honeywell APU RE220[GX]

**Subject:** Load Control Valve P/N 3291210-3 Filter Clean and Inspect

**Purpose:** To advise the field of possible contamination of Load Control Valve Filter P/N 3161666-3.

**Background:** Load Control Valve (LCV), P/N 3291210-3, utilizes APU bleed air to power open/close the LCV butterfly plate. The bleed air supply tube contains an inlet filter, P/N 3161666-3, to reduce the contamination into the LCV internal components. Due to the impurities contained in the bleed air, the inlet filter will become clogged over time.

**Discussion:** The Load Control Valve (LCV), P/N 3291210-3, is a pneumatically operated valve with electronic closed loop position feedback. The valve uses inlet pressure provided by the APU to pre-load the valve in the closed position. Inlet pressure is routed, through an inlet filter (post SB 49-7045), into the valve actuator closing chamber and to the supply nozzle of the torque motor. With no current applied to the torque motor, pressure cannot enter the actuator opening chamber, but will be vented to ambient through the torque motor vent. As current increases to the torque motor, air will be directed into the actuator opening chamber and the torque motor vent will be blocked. Increasing air pressure in the actuator opening chamber causes the butterfly plate to move towards the open position.

If the airflow through the inlet filter is impeded, operation of the valve can be affected. Extreme filter contamination may prevent the valve from opening to the commanded position.

Potential EICAS message for a clogged filter:

APU BLEED SYS FAIL

Potential CAIMS message:

LOAD CONT VLV [LCV POSITION VS CMD]

If operators are experiencing these faults on a regular basis, it is suggested by Honeywell to inspect the filter for contamination, using Figure 1 as a guide. If the filter shows signs of clogging, replace the filter or clean the filter per the LCV Component Maintenance Manual.

An Aircraft Maintenance Manual (AMM) task is being prepared and will be added at the next revision.

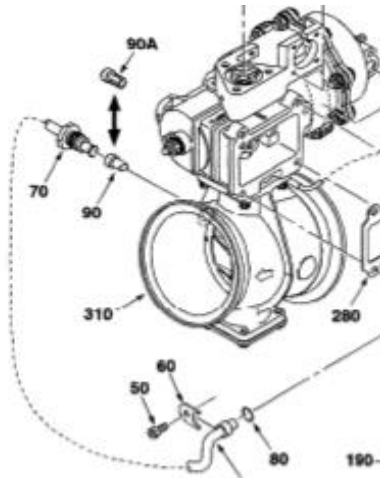

Z32B1210PL6

Figure 1

- 90A Filter P/N 3161666-3 (Post SB 49-7045)
- 90 Sensing Probe (Pre SB 49-7045)